

PLANT LOCATION

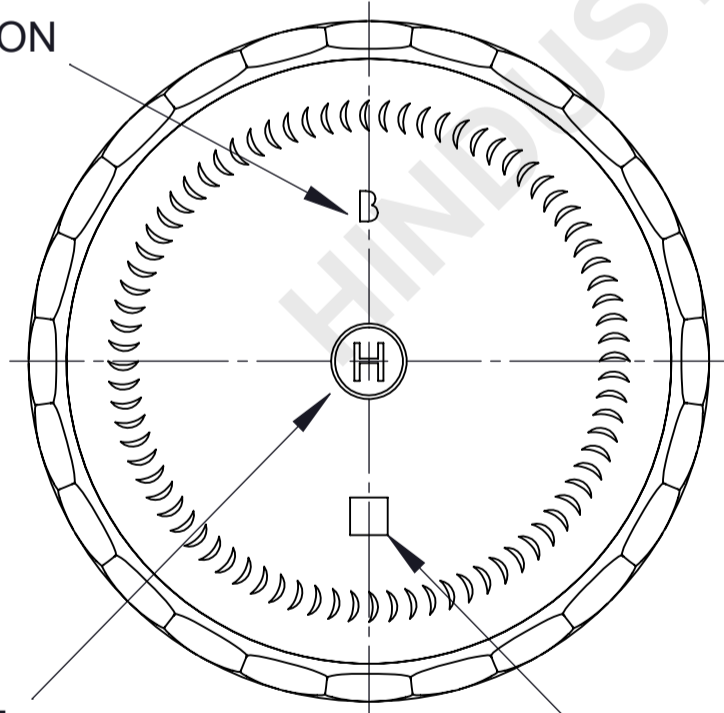

MFR'S SYMBOL

CAVITY NO.

ALL DIMENSIONS ARE IN MILLIMETERS

PROCESS	PRESS & BLOW										SPECIFICATION AGREEMENT ARE BASED ON TOLERANCED DIMENSIONS ONLY DO NOT SCALE DRAWING COPYRIGHT RESERVED. NOT TO BE COPIED IN WHOLE OR PART WITHOUT WRITTEN PERMISSION FROM H.N.G. & I. LTD.	
MINIMUM THROUGH BORE	-										HINDUSTHAN NATIONAL GLASS & IND. LTD.	
FILL POINT VERIFIED	NO										TITLE: 800 ML ROUND 82 MM LUG JAR	
TILT ANGLE	-	No.	REV.No.	REVISION			DATE	CHK	DRC		CUST:	CHECKED:
MAXIMUM DEPTH OF STANDARD ENGRAVING	-	FILL-POINT		-- ml ± ml							DRAWN:VIMLESH 10.01.2007	APPROVED:
MAX. GAS VOLUMES	-	BRIMFUL CAP.		820 ± 10 ML								
REF DRG No :-CD-5046		WEIGHT		315 ± 18 GMS.							DRAWING No. 42831	
MOULD EQUIPMENT ORDERED BY	FINISH	82 MM LUG GPI 2040			COLOUR	FLINT						A3 REV.
PLANT	B	SURFACE TREATMENT		NO			C.C. NO.	42831				