

FRONT VIEW

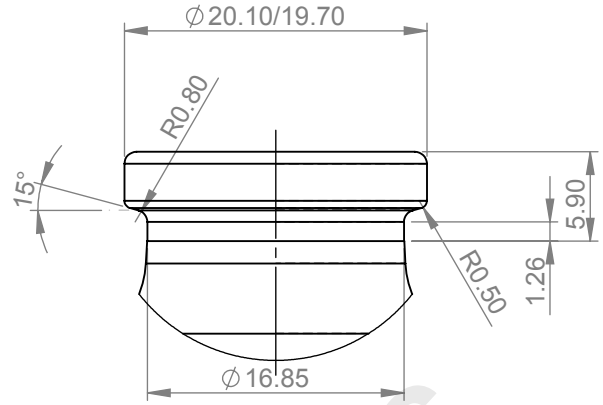

DETAIL C  
SCALE 2 : 1

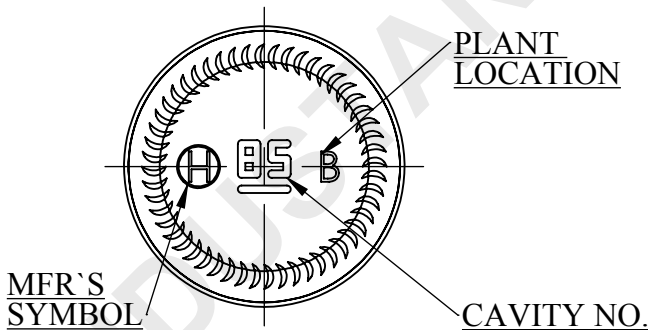

BOTTOM VIEW



ALL DIMENSIONS ARE IN MILLIMETERS

PROCESS	B&B	REV. No.	REV. BY.	REVISION	DATE	CHK	DRC	SPECIFICATION AGREEMENT ARE BASED ON TOLERANCED DIMENSIONS ONLY DO NOT SCALE DRAWING COPYRIGHT RESERVED. NOT TO BE COPIED IN WHOLE OR PART WITHOUT WRITTEN PERMISSION FROM H.N.G.& I. LTD.		
MINIMUM THROUGH BORE	(C)	(1)	RAHUL	DIGITAL CAVITY ADDED AND MFR'S SYMBOL'S POSITION CHANGED	17.11.15			HINDUSTHAN NATIONAL GLASS & IND. LTD.		
FILL POINT VERIFIED	NO	(B)		CAP 38±2ML WAS 37±2ML, WT & DIA CH.	02.08.15			TITLE 30ML SHORT HT. VIAL		
TILT ANGLE	—							CUST		
MAXIMUM DEPTH OF STANDARD ENGRAVING	—							DRN RAJESH DR. DT. 02.08.15		
MAX. GAS VOLUMES	—							CHK. CHK. DT.		
REF DRG No :-								APPD. APPD. DT.		
MOULD EQUIPMENT ORDERED BY								DRAWING No. 42669		
PLANT								COLOUR		A4 REV.
				SURFACE TREATMENT	NO			C.C. NO.		(C)